

PADDED PINNACLE™ SLING 100% LEATHER

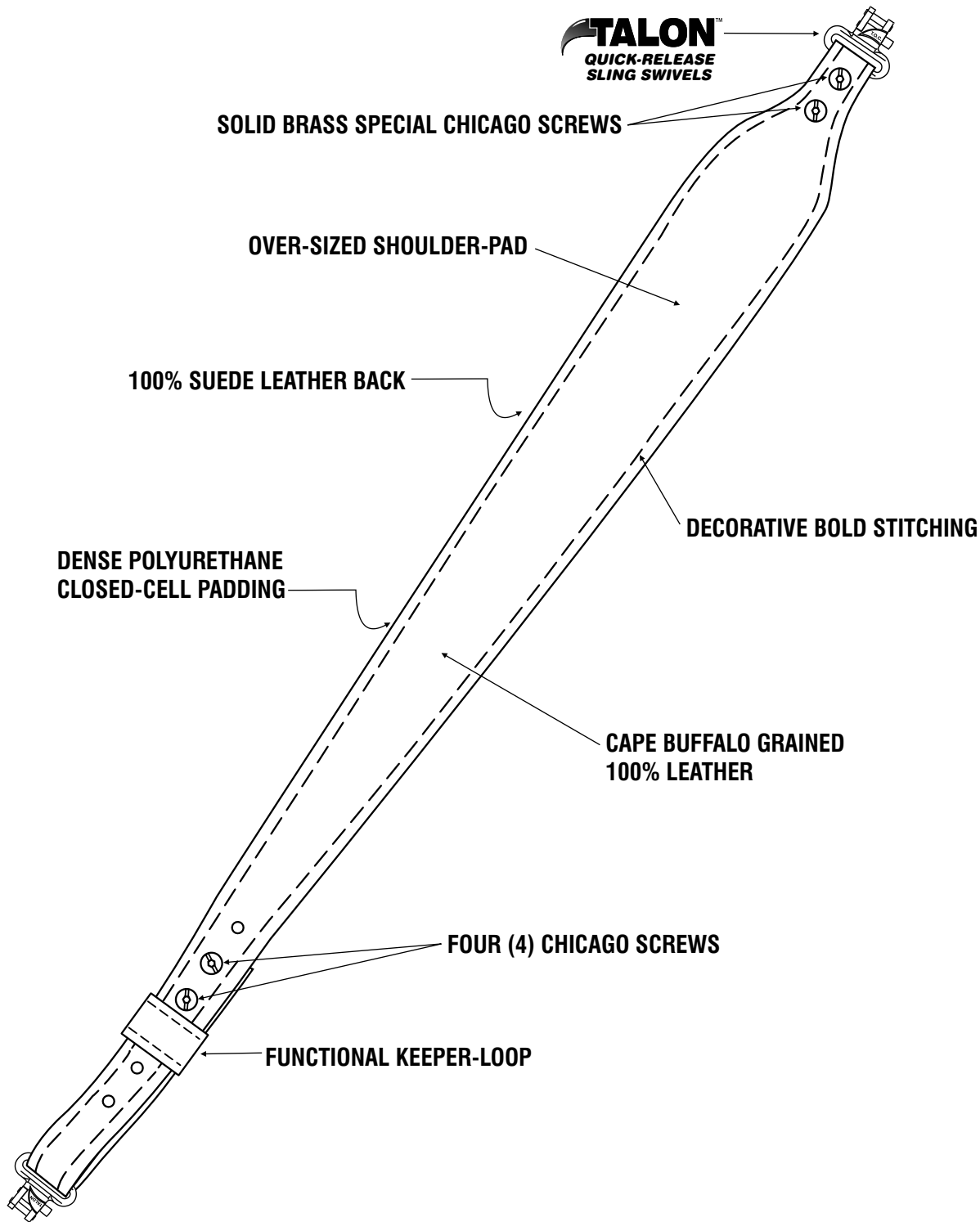

Firearm safety is your individual responsibility. You must carefully examine and be sure the firearm is unloaded. You must visually inspect the chamber and the magazine to make sure they are clear/empty. You must remove the cartridge clip, if present. These activities must be performed each time you install or remove The PINNACLE Firearm Sling with TALON Sling Swivels. This detailed information must be given to anyone using your PINNACLE Sling and TALON Sling Swivels..



GUARANTEED ∞ FOREVER



QUICK-RELEASE SLING SWIVELS



WARNING: Be sure the firearm is unloaded and safe before attaching or removing your **TALON** Sling Swivels!

INSTRUCTIONS:

- A.** Press the Spring-Loaded Pin inward to open the Rotating Gate, Fig. 1.
- B.** Rotate Gate 90 degrees to open while pressing inward on the Spring-Loaded Pin, Fig. 1.
- C.** Insert Swivel Base/Stud Pin into provided swivel base/stud on your firearm, Fig. 1.
- D.** To close the Rotating Gate depress the Spring-Loaded Pin while rotating the Gate 90 degrees to the fully closed/engaged position, as pictured, Fig. 2.
- E.** The Swivel Base/Stud Pin must pass completely through the hole at the end of the Rotating Gate, as pictured, Fig. 2.
- F.** The Rotating Gate must rest fully within the Off-Set in the swivel body, as pictured, Fig. 2.
- G.** No Gap or Open Space will be present in this area when the swivel is fully closed/engaged correctly, as pictured, Fig. 2.

Removal of The TALON Sling Swivels is accomplished by reversing the steps "A" through "G".

NOTICE:

- 1.** The swivels must be observed periodically to make sure the swivels are fully closed/engaged correctly each time you use your firearm.
- 2.** Pulling, tugging or stress of any kind upon the swivels, sling, firearm/scope must be given immediate attention to make sure the swivels remain in the correct/proper, closed/engaged position during any usage.
- 3.** You must never attempt to climb trees, tree stands, steep inclines, hills, rocks or leap/jump over ditches with a loaded firearm. The act of firearm and hunting safety is your responsibility.
- 4.** It is necessary for you to convey this information in detail to anyone who may use your **TALON Swivels**.
- 5.** Failure to follow the safety rules and recommendations set forth in this pamphlet could result in a swivel accidentally opening and becoming detached from the swivel base/stud. If this should occur, the firearm could fall, and could result in damage to the firearm/scope, accidental discharge, and/or cause injury and/or death to yourself and/or someone else.

Open Position (Fig. 1)

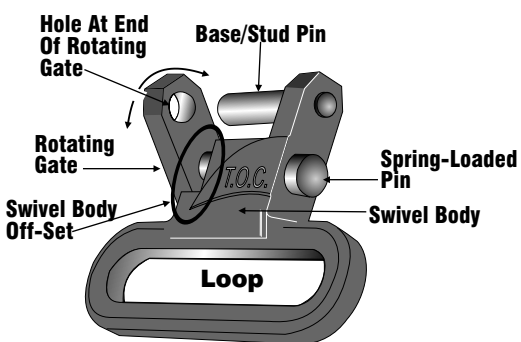

Fully Closed/Engaged Position (Fig. 2)

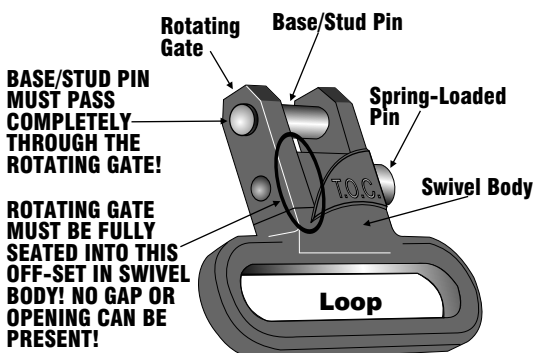

! CAUTION ! CAUTION ! CAUTION !

The **TALON** Sling Swivel must not be overloaded or improperly stressed. The **TALON** Sling Swivel must be examined periodically to insure correct installation. Correct installation of the **TALON** Sling Swivel requires:

- 1.** The Base/Stud Pin to pass completely through the hole at the end of the Rotating Gate, Fig. 2.
- 2.** The Rotating Gate must be positioned/seated into the Off-Set in the swivel body, in the closed/engaged position, Fig. 2.



The **TALON** Sling Swivel is a well designed mechanical device. Only superior materials and the most advanced techniques are used in manufacturing. The surface and the Spring-Loaded Pin cavity should be lightly oiled to prevent corrosion and retain good appearance and working order, as designed.